



R32

UW Wall-Mounted
Inverter Series - Qatar



In everything we do, we integrate sustainability



R32 Wall Mount Inverter Series

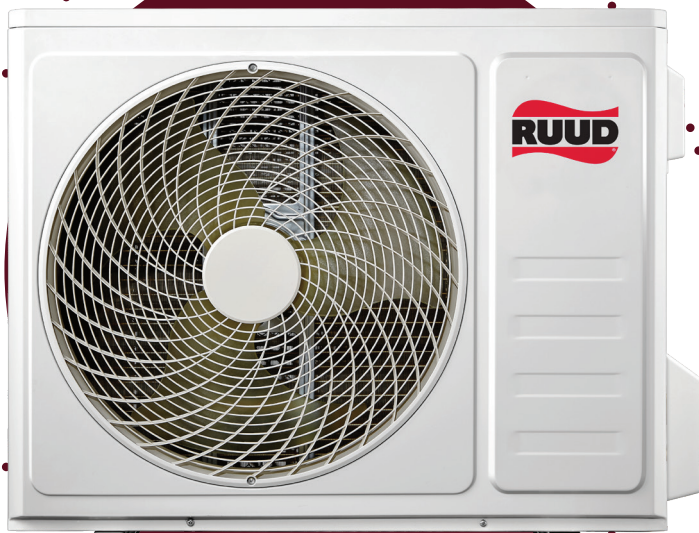

2035 goals

30%

GHG REDUCTION

Reduce emissions intensity by 30% throughout the entire lifecycle of Ruud products²



SUSTAINABLE

PACKAGING

Achieve an average of 90% reusable, recyclable, or compostable packaging OR at least 50% recycled content in product packaging³



10%

WASTE REDUCTION

Reduce global waste intensity (ton/unit) by 10%⁵



ZERO

WASTE TO LANDFILL

Maintain zero waste to landfill (ZWTL) at all factories and on-board new acquisitions⁴



1M+

TRAININGS

Complete 1 million trainings for plumbers, contractors, and key influencers globally on sustainable products, refrigerant management and / or sustainable best practices



Working Toward A Greater Degree™

Building upon the strong foundation set in 2019, our next generation of sustainability takes the familiarity of the original framework and simplifies it into Products, Process and People. These pillars provide a north star, helping us focus on innovating products with higher efficiency, manufacturing them in a process that reduces our direct use of resources, and supporting the people that recommend and install in homes and business around the globe.

1. Ruud's goal is to reduce greenhouse gas emissions by 30% by 2035 from a 2023 baseline. This metric will be based on intensity emissions normalized by revenue and includes Scopes 1-3 as defined by the Greenhouse Gas Protocol. At this time, these figures have not been independently verified by a third party.
2. Ruud measures reusable, recyclable, compostable, and recycled content in line with ISO and FTC standards. At this time, these figures have not been independently verified by a third party.
3. A Ruud plant is considered to have reached Zero Waste to Landfill when it achieves a rate of at least 90% diversion of nonhazardous solid waste away from landfill, waste-to-energy (WTE), and incineration, in line with the Zero Waste International Alliance standards and TRUE Zero Waste standards. At this time, these figures have not been independently verified by a third party.
4. Ruud measures waste intensity as a ratio of total weight of non-hazardous waste generated across all manufacturing facilities to total units produced from a 2023 baseline. At this time, these figures have not been independently verified by a third party.

R32

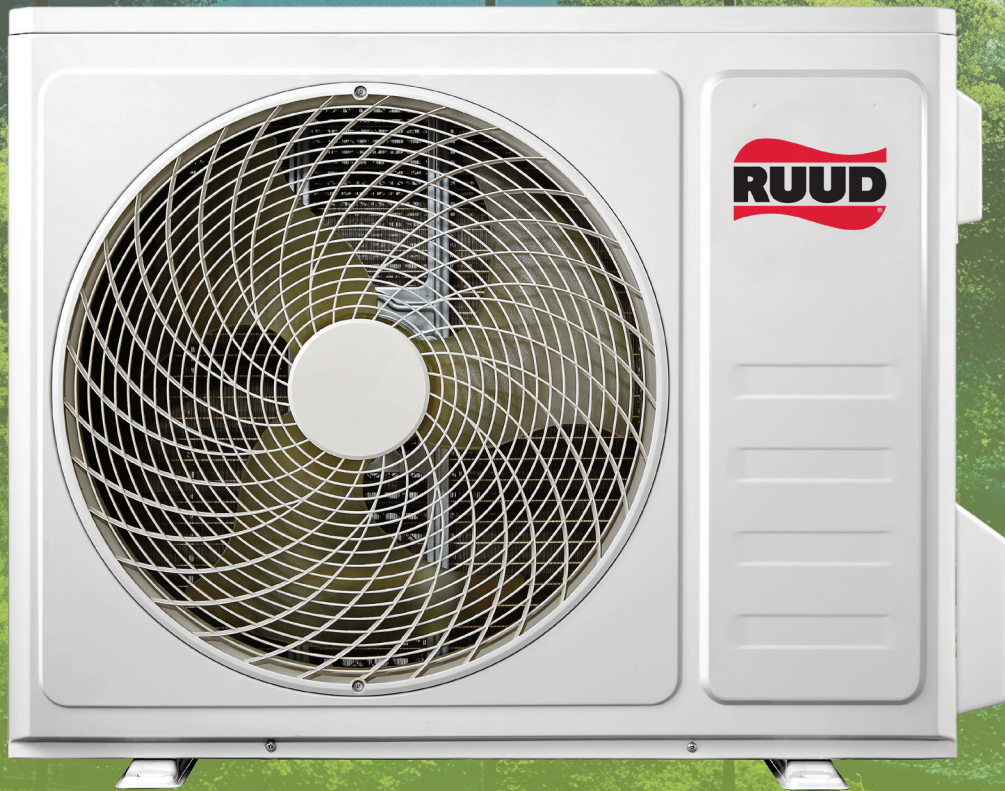

Smart Cooling Powered by R32

This air conditioner uses R32 refrigerant, a modern cooling gas that's more efficient and kinder to the environment. R32 helps your home cool faster while using less energy, and it produces fewer emissions than older refrigerants. It's an important step toward cleaner, more sustainable comfort for you and your family.

NOMENCLATURE

System Model Name

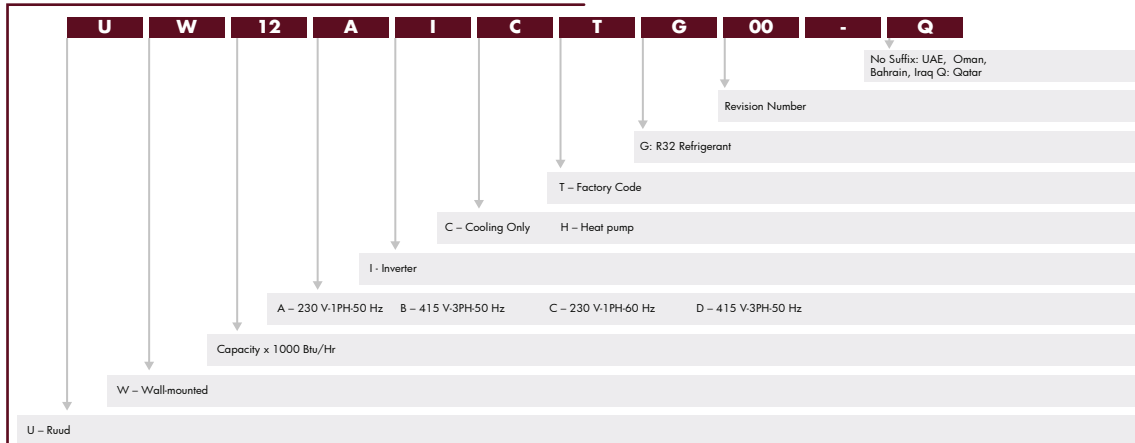

Indoor Model Name

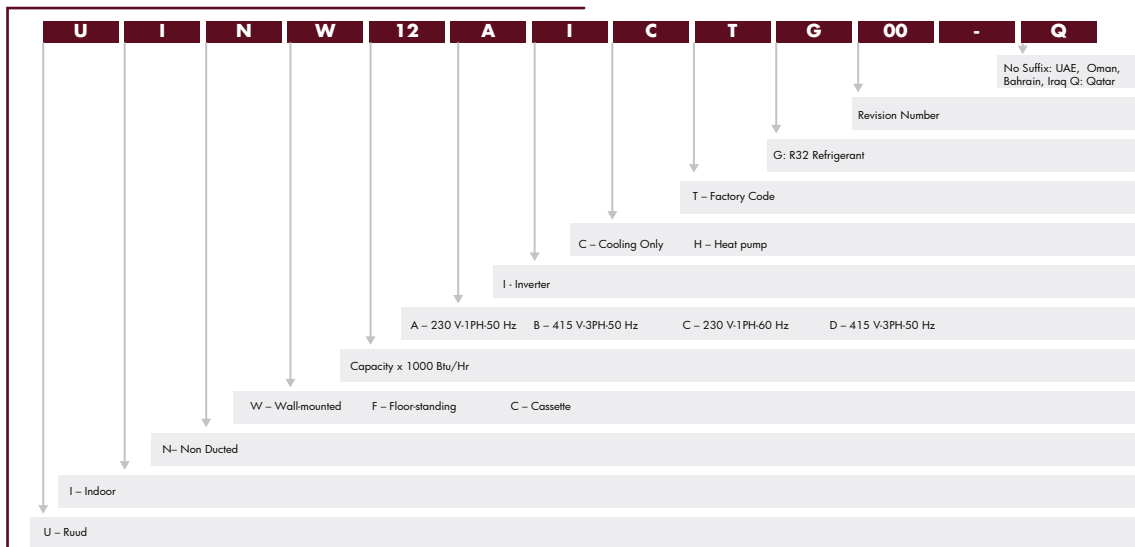

Outdoor Model Name

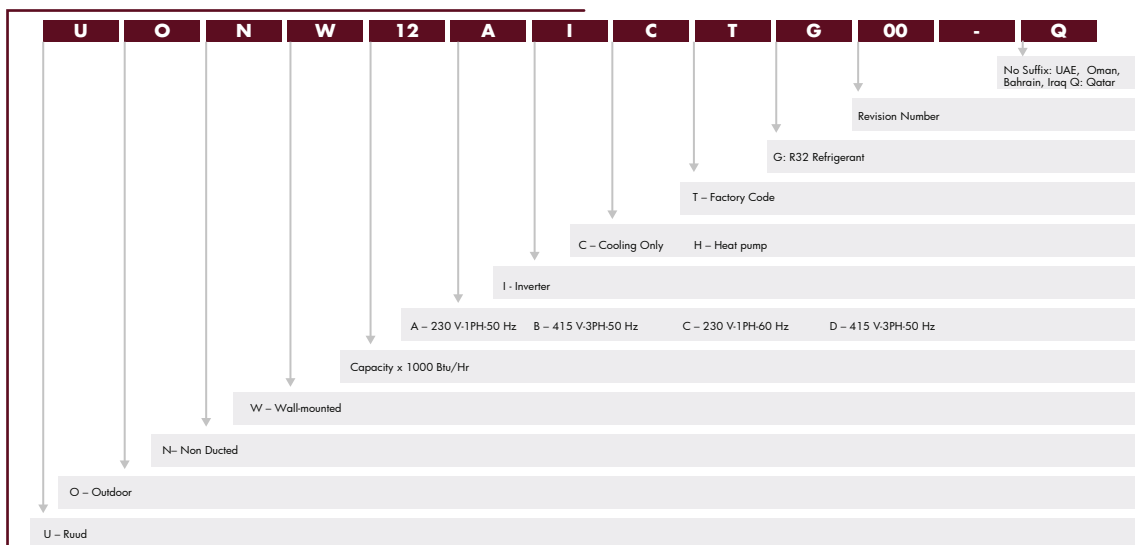

SPLIT AIR-CONDITIONER PANELS



UW12AICTG00-Q

UW18AICTG00-Q

UW24AICTG00-Q

UW30AICTG00-Q



UW36AICTG00-Q

Features

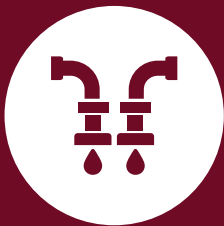

Dual Drainage

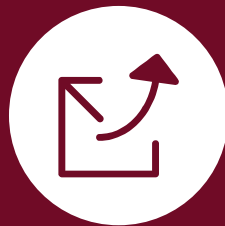

Louver Position Memory



Self-diagnosis



Low Noise



Rust Proof

FEATURES



**High Efficiency DC
Inverter T3 Compressor**



**High Ambient
Operation Up to 60°C**

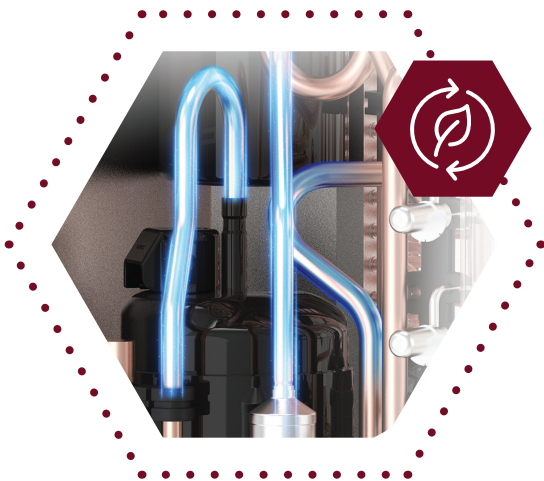

**Less Refrigerant
Charge Requirement**



**Auto
Dust Removal**

RAPID COOLING AND HEATING



Cool Wind Blowing Out



18°C



30s

In Cooling Mode

Outlet Temperature Decreased Rapidly in 30"

Fan
Defrosting



Frosting



Defrosting
Evaporator



Fan
Drying



Automatic Self Cleaning

The indoor cleans itself automatically by frosting, fan defrosting, and fan drying ensuring cleaner air and healthier breathing environment.

*Cooling Only DC Inverter Only

UNIQUE AIR-COOLED TECHNOLOGY

Because of the negative pressure generated by the outdoor fan, the outdoor cooler air is flow through the PCB box via compressor cavity in order to cool down the electric parts of the outdoor unit allowing the unit to operate at ambient conditions up to 60C.

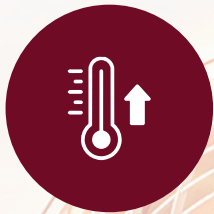

52° C
Strong Cooling



60° C
Nonstop Cooling

Capacity Comparison in High Ambient Temperature

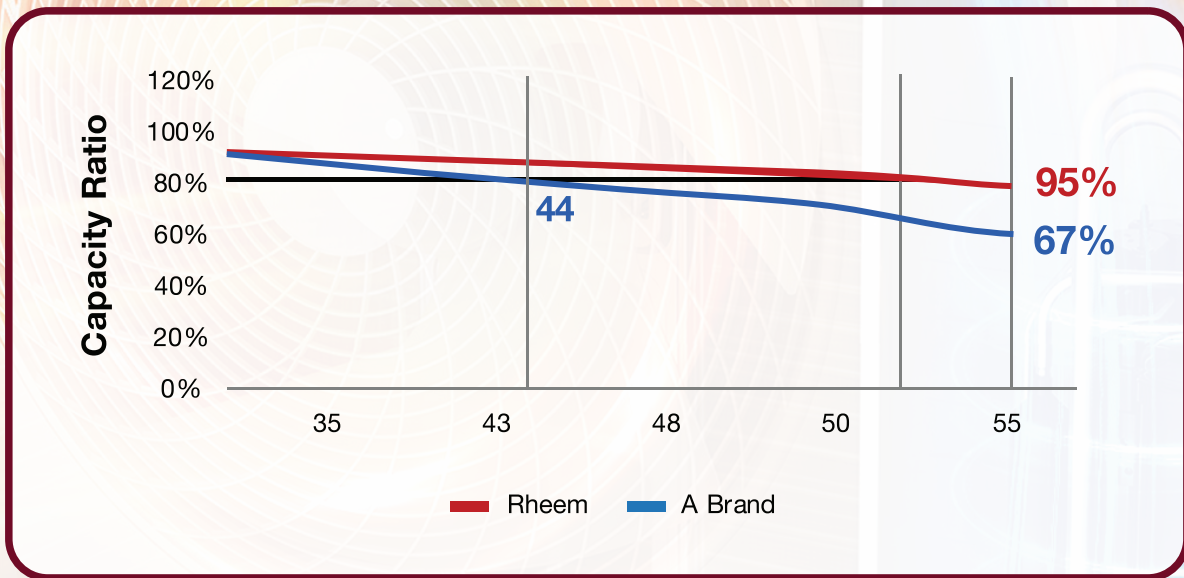

- Ruud model can keep full cooling capacity as rated in **52° C** , but A brand just in **44° C**
- In 55°C ambient, Ruud model can keep **95%** rated cooling capacity, but A brand just **67%**

(*Reference 18K model)

WI-FI CONNECTIVITY

Vector Precision Air Supply

Various precise fixed angles of air supply can provide more comfortable choices for users.

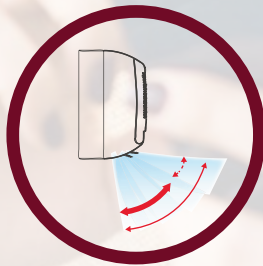

3 Swing Types (Vertical)

- Whole-house swing
- - - Upside swing
- Downside swing

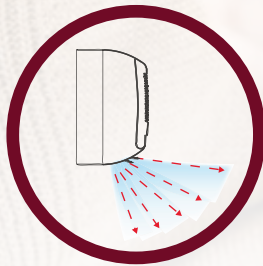

5 Blow Types (Vertical)

- - - Fix direction of air blow

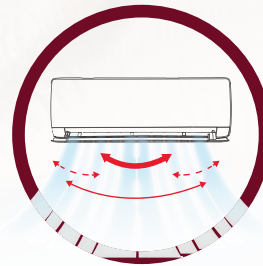

4 Swing Types (Horizontal)

- Whole-house swing
- Side Swing (L-R)
- Middle Swing

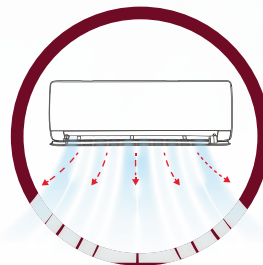

5 Blow Types (Horizontal)

- - - Fix direction of air blow

ENERGY SAVING EXPERIENCE

Full DC Inverter System

A DC inverter air-conditioner varies the compressor rotation speed to provide a precise method of maintaining the set temperature.



Fast Cooling

DC inverter air-conditioner enables the compressor to achieve maximum frequency in the shortest time from start up. It cools down 15% faster than conventional non-inverter air-conditioner.

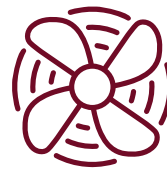

Precise Cooling

A DC inverter air-conditioner varies the compressor rotation speed to provide a precise method of maintaining the set temperature.

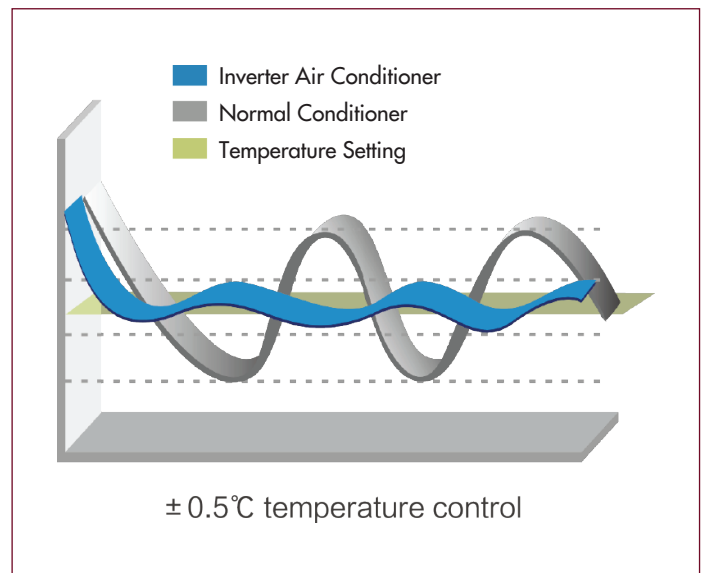
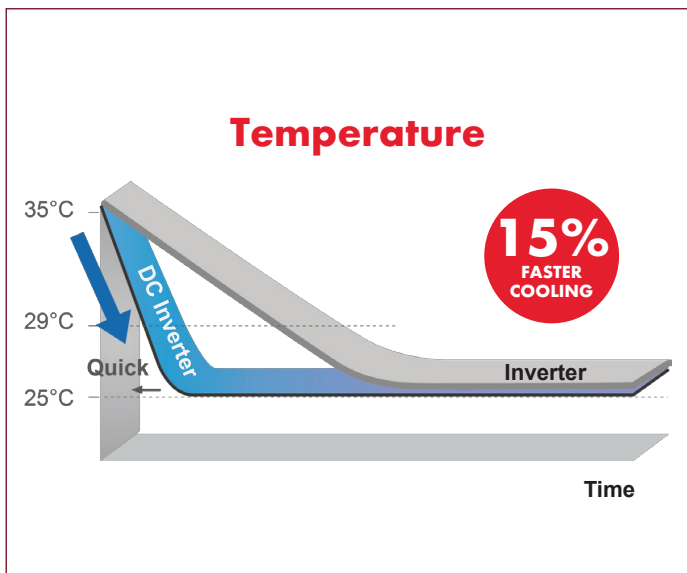

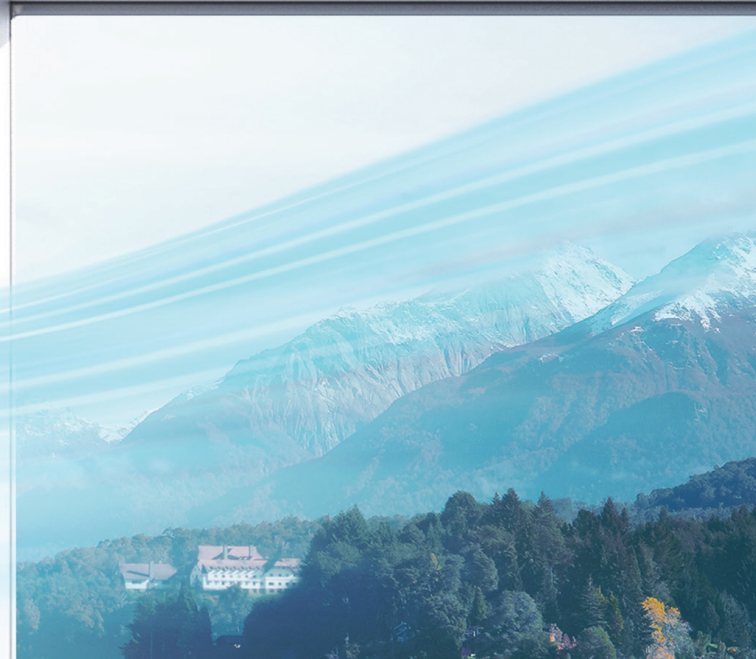
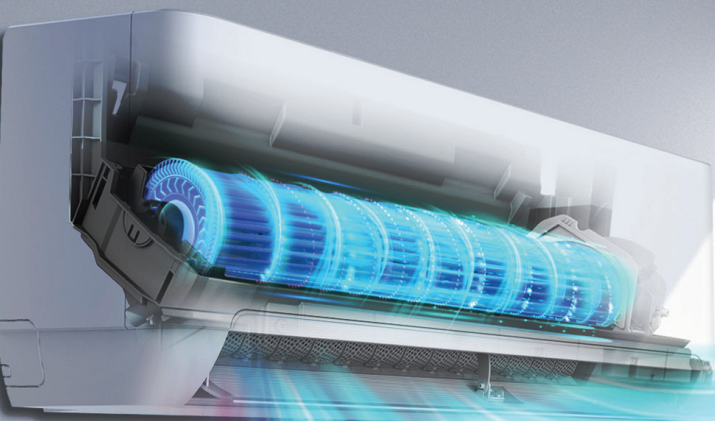

OTHER FEATURES



Smart Air Flow

In cooling mode, the cool air is blowing towards the ceiling to provide a shower-style cooling experience. In heating mode, the warm air is blowing towards the floor to provide a blanket-style heating experience.



Low Temperature Heating

Keeps you warm even when the outdoor temperature is as low as -30C.

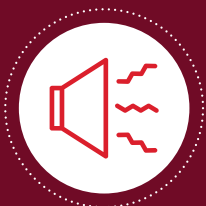

Low Noise Cooling

No more annoying sound from sudden speed changes and turning on/off of an air conditioner. Ruud's DC inverter unit ensures low noise operation at different conditions.



Better Safety Design

No connection between condensate water and electricity. BMC fireproof electric control box is applied, which creates high heat resistance & erosion resistance.

CONDENSING UNIT FEATURES

Strong resistant metal plates of rust & corrosion, maintaining its excellent performance in difficult climate such as humid, coastal, etc.

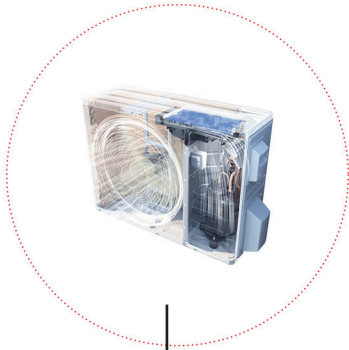

Inner **grooved cooper pipe** of more efficient heat exchanging.

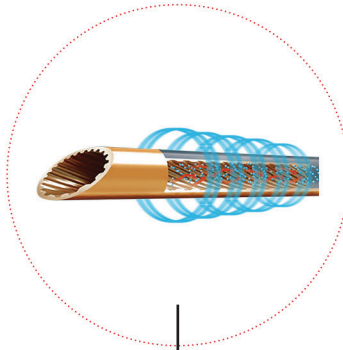

Coated PCB with strong anti-corrosion, anti-oxidation & anti-rust.

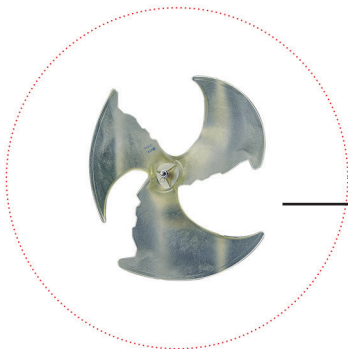
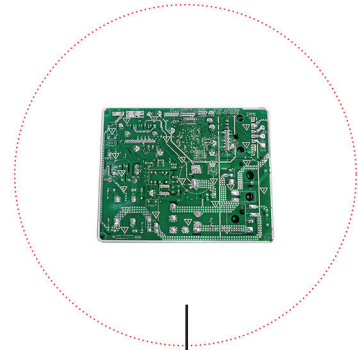

Bionic propeller fan with lower operation noise and higher air volume.

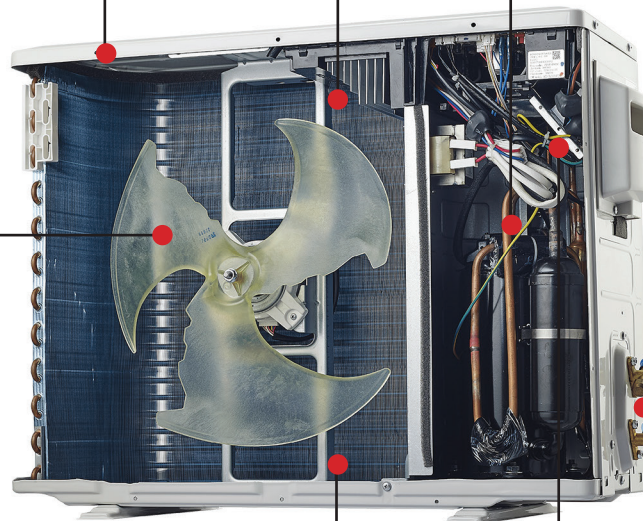

Tougher **valve protection** can provide better protection for the connection valves.

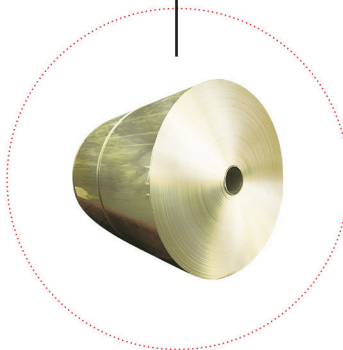

Excellent **hydrophilia coated fins** with less accumulation of dust, bacteria, etc.



Flanging processed plate **metal - protecting wiring** from damage of sharp edge.



REMOTE CONTROLLER FEATURES

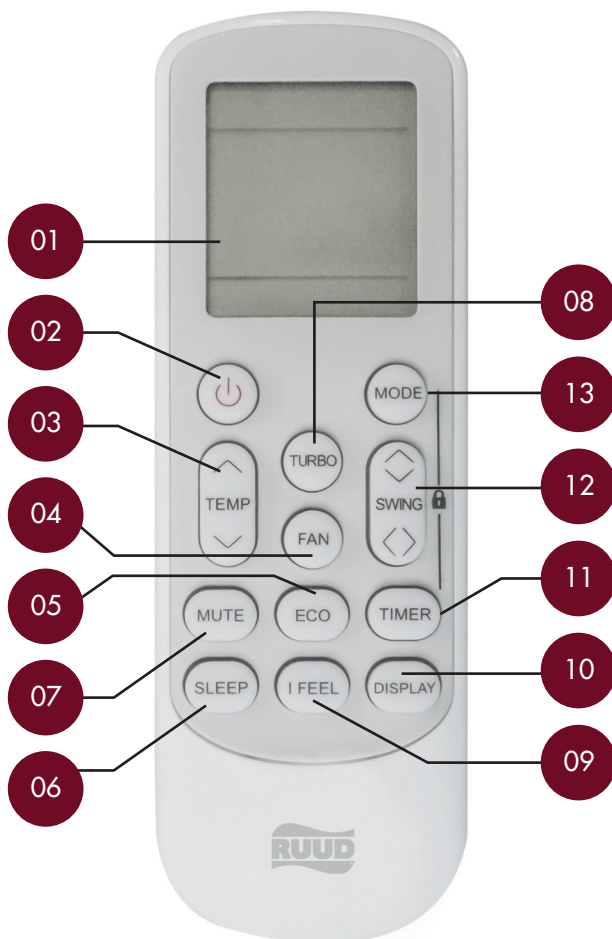

- 01 LED Display Screen
- 02 ON/OFF
- 03 Temperature Setting
- 04 Fan Speed Setting
- 05 Eco Mode
- 06 Sleep Mode
- 07 Mute Mode
- 08 Turbo
- 09 I Feel
- 10 LED Display (ON/OFF)
- 11 Timer Setting
- 12 Swing (Horizontal/Vertical)
- 13 Mode Setting (AUTO/COOL/ DRY/FAN/HEAT)

I FEEL

The in-built additional temperature sensor in the remote controller monitors the surrounding temperature. Therefore, the air-conditioner can adjust the room temperature more accurately and provide extra comfort to users.

ECO

By activating the ECO mode, the air conditioner will automatically work in the most efficient and energy - saving way, while maintaining the most comfortable experience in the living room.

FEATURES SUMMARY

Range	12K	18K	24K	30K	36K
Sleep	●	●	●	●	●
Clock (Real Time)	-	-	-	-	-
Timer ON/OFF	●	●	●	●	●
Vertical Swing (Motorized or Manual)	●	●	●	●	●
Horizontal Swing (Motorized or Manual)	●	●	●	●	●
Energy Saving	●	●	●	●	●
Air Flow Direction Control	●	●	●	●	●
Memory	●	●	●	●	●
Autorestart	●	●	●	●	●
IFeel	●	●	●	●	●
Turbo Cooling	●	●	●	●	●
Self Clean / Blow	●	●	●	●	-
Self Diagnosis (Error Code)	●	●	●	●	●
Remote LCD	●	●	●	●	●
Filter Configuration	●	●	●	●	●
Intelligent Defrost	-	-	-	-	-
Filter Dirty Alarm	●	●	●	●	●
Cold Plasma or Ioniser	○	○	○	○	○
Children Lock	●	●	●	●	●
Evaporator Fins	Golden	Golden	Golden	Golden	Golden
Condenser Fins	Golden	Golden	Golden	Golden	Golden
Max Piping Capability Total (Metre)	25	30	30	30	30
Max Piping Capability Vertical (Metre)	15	20	20	20	20

● Standard ○ Optional - N/A

R32 COOL ONLY INVERTER SPECIFICATIONS

Capacity Class			12K	18K	24K	30K	36K
Type			Cooling Only	Cooling Only	Cooling Only	Cooling Only	Cooling Only
			Inverter with R32	Inverter with R32	Inverter with R32	Inverter with R32	Inverter with R32
System Model Number			RW12AICTG00-Q	RW18AICTG00-Q	RW24AICTG00-Q	RW30AICTG00-Q	RW36AICTG00-Q
Indoor Model Name			RINW12AICTG00-Q	RINW18AICTG00-Q	RINW24AICTG00-Q	RINW30AICTG00-Q	RINW36AICTG00-Q
Outdoor Model Name			RONW12AICTG00-Q	RONW18AICTG00-Q	RONW24AICTG00-Q	RONW30AICTG00-Q	RONW36AICTG00-Q
Rated cooling capacity(T1)		Btu/h	12100(2559~15354)	18100(4436~20131)	22100(3412~26272)	28200(5800~34120)	33000(5800~37532)
Rated cooling capacity(T1)		W	3540(750~4500)	5310(1300~5900)	6480(1000~7700)	8250(1700~10000)	9650(1700~11000)
Rated cooling capacity(T3)		Btu/h	11500(2559~12624)	16800(5118~18766)	20500(5118~23202)	24600(5800~30708)	30000(5800~32073)
Rated cooling capacity(T3)		W	3360(750~3700)	4920(1500~5500)	6000(1500~6800)	7200(1700~9000)	8800(1700~9400)
EER for cooling(T1)		Btu/h~W;	12.20	11.95	12.35	11.85	12.15
EER for cooling(T1)		W/W	3.58	3.50	3.62	3.47	3.56
EER for cooling(T3)		Btu/h~W;	9.05	8.85	8.95	9.3	9.05
EER for cooling(T3)		W/W	2.65	2.59	2.62	2.73	2.65
Moisture removal		Liters/h	1.2	1.8	2.2	2.8	3.3
Pressure	High(DP)	MPa	4.5	4.5	4.5	4.5	4.5
	Low(SP)	MPa	1.9	1.9	1.9	1.9	1.9
Indoor noise level at cooling	Super	dB(A)	46.0	49.0	50.0	55.0	55.0
	High	dB(A)	43.0	46.0	48.0	53.0	53.0
	Med.	dB(A)	37.0	41.0	42.0	47.0	47.0
	Low	dB(A)	32.0	36.0	37.0	42.0	38.0
	Quite	dB(A)	28.0	32.0	32.0	40.0	35.0
Outdoor noise level		dB(A)	53.0	56.0	59.0	61.0	60.0
Power supply			220-240V~1 Phase/ 50/60Hz	220-240V~1 Phase/ 50/60Hz	220-240V~1 Phase/ 50/60Hz	220-240V~1 Phase/ 50/60Hz	220-240V~1 Phase/ 50/60Hz
Voltage Range		V	198~264	198~264	198~264	198~264	198~264
Current	Cooling(T1)	A	6.3(1.1~9.0)	6.9(1.2~12.0)	8.0(1.5~15.0)	10.6(2.0~18.0)	12.0(2.0~19.0)
	Cooling(T3)	A	8.0(1.1~9.0)	8.6(1.2~12.0)	10.3(1.5~15.0)	11.9(2.0~18.0)	14.7(2.0~19.0)
Power input	Cooling(T1)	W	991	1513	1788	2375	2715
	Cooling(T3)	W	1270	1903	2296	2649	3317
Refrigerant		kg	R32/0.49	R32/0.72	R32/0.82	R32/0.97	R32/1.07
Compressor	Type		Inverter	Inverter	Inverter	Inverter	Inverter
Expansion device			Capillary tube	Capillary tube	Capillary tube	EEV	EEV
Indoor airflow		m ³ /h	740/680/590/540/450/420/390	1000/940/860/780/720/660/550	1500/1410/1290/1180/1080/1000/820	1700/1600/1470/1330/1230/1130/930	1900/1750/1650/1540/1430/1320/1160
Connecting Pipe	Gas	Inches	Φ9(3/8")	Φ9(3/8")	Φ12(1/2")	Φ15.88(5/8")	Φ15.88(5/8")
	Liquid	Inches	Φ6(1/4")	Φ6(1/4")	Φ6(1/4")	Φ6(1/4")	Φ6(1/4")
Connecting Wiring	Size x Core number		4x1.0	4x1.5	4x0.75	4x0.75	4x0.75
Drainage Pipe			O.D 16mm	O.D 16mm	O.D 16mm	O.D 16mm	O.D 16mm
Net dimensions (W x D x H)	Indoor	mm	910×206×294	1010×220×315	1010×220×315	1191×258×360	1400×280×370
	Outdoor	mm	795×305×549	853×349×602	920×380×699	920×380×699	967×421×803
Net weight	Indoor	kg	9	11	11.5	16	21
	Outdoor	kg	22	29.5	37.5	39	43.5
Packing dimensions (W x D x H)	Indoor	mm	979×277×372	1096×297×390	1096×297×390	1260×328×430	1495×385×465
	Outdoor (WOP)	mm	835×328×575	890×385×628	960×430×732	960×430×732	1022×480×835
	Outdoor (WP)	mm	835×340×585	890×385×628	960×430×732	960×430×732	1022×480×835
Gross weight	Indoor	kg	11.5	13.5	14.0	20.0	26.5
	Outdoor (WOP)	kg	24.0	32.5	41.5	43.0	48.5
	Outdoor (WP)	kg	25.0	33.5	42.5	44.5	50.5
Stuffing qty	40'HQ (WOP)	sets	250	195	150	126	82
	40'HQ (WP)	sets	245	195	150	126	82

PERFORMANCE TABLES (R32 COOL ONLY INVERTER)

UW12AICTG00

Indoor Temperature						Outdoor Temperature									
AFR (CFM)	EWB (°C)	EDB (°C)	TC	35°			40°			46°			52°		
				SC	PI	TC	SC	PI	TC	SC	PI	TC	SC	PI	
250	16	22	3.118	2.654	0.981	2.998	2.496	1.049	2.901	2.579	1.221	2.680	1.872	1.291	
	17.2	22	3.142	2.631	0.984	3.033	2.529	1.052	2.922	2.623	1.224	2.693	1.886	1.292	
	16	24.4	3.151	2.702	0.983	3.045	2.569	1.051	2.947	2.645	1.225	2.720	1.944	1.293	
	17.2	24.4	3.162	2.715	0.984	3.100	2.645	1.060	2.980	2.689	1.234	2.800	1.986	1.294	
	22	24.4	3.301	2.996	0.986	3.211	2.765	1.060	3.052	2.831	1.235	2.852	2.064	1.295	
	16	27	3.356	3.034	0.987	3.269	2.934	1.061	3.129	2.890	1.236	2.875	2.124	1.295	
	19	27	3.377	3.090	0.988	3.312	2.999	1.061	3.184	3.003	1.236	2.991	2.246	1.296	
	22	27	3.383	3.094	0.990	3.317	2.997	1.062	3.188	3.006	1.240	2.997	2.253	1.297	
	16	29	3.383	3.020	0.991	3.319	2.931	1.063	3.191	2.993	1.239	3.000	2.186	1.297	
	19	29	3.389	3.048	0.992	3.324	2.954	1.063	3.195	3.011	1.236	3.002	2.204	1.297	
	22	29	3.393	3.051	0.993	3.337	2.964	1.064	3.231	3.032	1.237	3.024	2.205	1.298	
	16	22	3.349	2.797	0.996	3.279	2.858	1.067	3.178	2.996	1.114	2.974	2.018	1.305	
310	17.2	22	3.360	2.815	0.996	3.290	2.878	1.067	3.192	3.012	1.117	2.984	2.028	1.306	
	16	24.4	3.371	2.832	0.997	3.308	2.898	1.067	3.206	3.039	1.120	2.997	2.042	1.306	
	17.2	24.4	3.384	2.852	0.997	3.319	2.921	1.068	3.215	3.064	1.120	3.009	2.055	1.307	
	22	24.4	3.397	2.869	0.998	3.333	2.931	1.068	3.224	3.092	1.121	3.024	2.064	1.309	
	16	27	3.408	2.845	0.998	3.341	2.957	1.068	3.234	3.039	1.127	3.040	2.076	1.310	
	19	27	3.417	2.858	0.999	3.359	2.983	1.069	3.257	3.064	1.243	3.082	2.091	1.311	
	22	27	3.451	2.880	0.999	3.391	3.001	1.070	3.287	3.092	1.244	3.086	2.167	1.312	
	16	29	3.499	3.092	1.000	3.416	3.064	1.071	3.302	3.125	1.244	3.096	2.215	1.312	
	19	29	3.510	3.253	1.000	3.449	3.157	1.070	3.315	3.183	1.245	3.114	2.360	1.314	
	22	29	3.528	3.263	1.001	3.456	3.160	1.072	3.322	3.201	1.246	3.121	2.356	1.319	
	16	22	3.397	2.962	1.004	3.348	2.884	1.079	3.241	3.092	1.252	3.080	2.148	1.328	
	17.2	22	3.411	2.972	1.004	3.362	2.894	1.080	3.259	3.112	1.253	3.096	2.162	1.329	
400	16	24.4	3.430	2.982	1.005	3.380	2.908	1.080	3.273	3.135	1.254	3.119	2.174	1.331	
	17.2	24.4	3.467	3.009	1.006	3.396	2.929	1.081	3.289	3.147	1.253	3.144	2.201	1.330	
	22	24.4	3.526	3.287	1.007	3.456	3.160	1.082	3.332	3.141	1.255	3.163	2.339	1.338	
	16	27	3.594	3.352	1.007	3.510	3.220	1.084	3.371	3.155	1.255	3.190	2.324	1.340	
	19	27	3.664	3.424	1.008	3.608	3.323	1.084	3.504	3.307	1.256	3.292	2.441	1.341	
	22	27	3.673	3.433	1.011	3.616	3.330	1.086	3.510	3.316	1.259	3.297	2.445	1.342	
	16	29	3.675	3.373	1.011	3.619	3.328	1.086	3.513	3.320	1.258	3.299	2.448	1.343	
	19	29	3.677	3.377	1.010	3.622	3.328	1.087	3.517	3.409	1.250	3.304	2.399	1.334	
	22	29	3.697	3.394	1.013	3.640	3.344	1.090	3.532	3.423	1.255	3.318	2.409	1.339	

UW12AIHTG00

Indoor Temperature						Outdoor Temperature									
AFR (CFM)	EWB (°C)	EDB (°C)	TC	35°			40°			46°			52°		
				SC	PI	TC	SC	PI	TC	SC	PI	TC	SC	PI	
240	16	22	3.014	2.644	0.946	2.898	2.487	1.012	2.708	2.381	1.176	2.502	1.728	1.243	
	17.2	22	3.037	2.621	0.949	2.932	2.520	1.015	2.728	2.421	1.179	2.514	1.741	1.244	
	16	24.4	3.046	2.692	0.948	2.943	2.560	1.014	2.751	2.442	1.180	2.539	1.794	1.246	
	17.2	24.4	3.056	2.706	0.949	2.997	2.635	1.022	2.782	2.483	1.189	2.614	1.833	1.246	
	22	24.4	3.191	2.986	0.951	3.104	2.755	1.022	2.849	2.613	1.189	2.662	1.905	1.247	
	16	27	3.244	3.023	0.952	3.160	2.924	1.023	2.921	2.668	1.190	2.684	1.960	1.248	
	19	27	3.264	3.079	0.953	3.201	2.989	1.023	2.972	2.772	1.190	2.792	2.073	1.248	
	22	27	3.270	3.083	0.955	3.206	2.987	1.024	2.976	2.775	1.194	2.798	2.080	1.249	
	16	29	3.274	3.009	0.955	3.209	2.921	1.025	2.979	2.763	1.193	2.801	2.018	1.249	
	19	29	3.276	3.037	0.956	3.213	2.943	1.025	2.983	2.780	1.191	2.803	2.034	1.250	
	22	29	3.393	3.040	0.957	3.226	2.954	1.026	3.016	2.799	1.192	2.822	2.036	1.250	
	16	22	3.237	2.788	0.960	3.170	2.848	1.029	2.967	2.766	1.073	2.776	1.863	1.257	
300	17.2	22	3.248	2.805	0.961	3.181	2.868	1.029	2.980	2.781	1.076	2.785	1.872	1.258	
	16	24.4	3.259	2.822	0.961	3.198	2.887	1.029	2.993	2.805	1.078	2.798	1.885	1.258	
	17.2	24.4	3.271	2.842	0.961	3.209	2.911	1.029	3.001	2.828	1.079	2.809	1.897	1.258	
	22	24.4	3.283	2.859	0.962	3.222	2.921	1.030	3.009	2.854	1.079	2.822	1.905	1.261	
	16	27	3.294	2.835	0.963	3.229	2.947	1.030	3.019	2.805	1.085	2.838	1.916	1.262	
	19	27	3.303	2.848	0.963	3.247	2.972	1.030	3.040	2.828	1.197	2.877	1.930	1.263	
	22	27	3.337	2.869	0.964	3.278	2.990	1.031	3.068	2.854	1.198	2.880	2.000	1.263	
	16	29	3.383	3.081	0.965	3.303	3.053	1.033	3.083	2.885	1.198	2.890	2.045	1.264	
	19	29	3.393	3.241	0.965	3.334	3.146	1.032	3.095	2.939	1.200	2.907	2.178	1.266	
	22	29	3.411	3.252	0.965	3.341	3.149	1.034	3.101	2.955	1.200	2.913	2.175	1.271	
	16	22	3.283	2.951	0.968	3.236	2.874	1.041	3.025	2.854	1.206	2.875	1.982	1.279	
	17.2	22	3.298	2.962	0.968	3.250	2.884	1.041	3.042	2.872	1.207	2.890	1.996	1.280	
380	16	24.4	3.315	2.972	0.969	3.268	2.897	1.042	3.055	2.894	1.208	2.912	2.007	1.282	
	17.2	24.4	3.352	2.998	0.970	3.283	2.919	1.042	3.071	2.905	1.207	2.934	2.032	1.281	
	22	24.4	3.408	3.276	0.971	3.341	3.149	1.043	3.110	2.900	1.209	2.953	2.159	1.289	
	16	27	3.475	3.340	0.971	3.393	3.209	1.045	3.146	2.912	1.208	2.978	2.145	1.291	
	19	27	3.542	3.412	0.972	3.488	3.311	1.045	3.271	3.053	1.210	3.073	2.254	1.292	
	22	27	3.551	3.421	0.974	3.496	3.318	1.047	3.277	3.061	1.212	3.078	2.257	1.293	
	16	29	3.553	3.361	0.974	3.498	3.316	1.047	3.279	3.064	1.212	3.080	2.259	1.293	
	19	29	3.555	3.365	0.974	3.501	3.317	1.048	3.283	3.147	1.204	3.085	2.215	1.285	
	22	29	3.574	3.382	0.977	3.518	3.332	1.052	3.297	3.160	1.209	3.097	2.224	1.290	

PERFORMANCE TABLES (R32 COOL ONLY INVERTER)

UW18AICTG00

Indoor Temperature						Outdoor Temperature								
AFR (CFM)	EWB (°C)	EDB (°C)	35°			40°			46°			52°		
			TC	SC	PI	TC	SC	PI	TC	SC	PI	TC	SC	PI
390	16	22	4.639	3.973	1.507	4.460	3.737	1.611	4.231	3.701	1.897	3.908	2.686	2.005
	17.2	22	4.675	3.939	1.512	4.512	3.787	1.616	4.262	3.763	1.901	3.927	2.706	2.007
	16	24.4	4.688	4.045	1.509	4.530	3.846	1.614	4.297	3.796	1.903	3.966	2.789	2.009
	17.2	24.4	4.704	4.066	1.511	4.612	3.960	1.627	4.346	3.859	1.918	4.084	2.849	2.010
	22	24.4	4.911	4.486	1.515	4.777	4.140	1.628	4.451	4.062	1.919	4.159	2.961	2.011
	16	27	4.993	4.543	1.515	4.863	4.393	1.629	4.563	4.147	1.920	4.193	3.047	2.012
	19	27	5.024	4.626	1.517	4.927	4.491	1.630	4.643	4.310	1.920	4.362	3.222	2.013
	22	27	5.032	4.632	1.520	4.934	4.488	1.631	4.650	4.313	1.926	4.371	3.233	2.014
	16	29	5.038	4.522	1.522	4.938	4.389	1.633	4.653	4.294	1.924	4.376	3.137	2.015
	19	29	5.042	4.563	1.523	4.945	4.423	1.633	4.660	4.321	1.921	4.378	3.163	2.016
	22	29	5.048	4.568	1.525	4.965	4.438	1.634	4.711	4.351	1.922	4.409	3.164	2.017
	16	22	4.982	4.189	1.529	4.879	4.279	1.638	4.635	4.299	1.731	4.437	2.896	2.027
460	17.2	22	4.999	4.214	1.530	4.895	4.309	1.639	4.655	4.323	1.735	4.352	2.910	2.028
	16	24.4	5.015	4.240	1.531	4.922	4.339	1.639	4.675	4.361	1.739	4.371	2.930	2.029
	17.2	24.4	5.034	4.270	1.531	4.938	4.374	1.639	4.689	4.396	1.740	4.389	2.949	2.030
	22	24.4	5.053	4.296	1.533	4.959	4.389	1.640	4.701	4.437	1.741	4.409	2.961	2.034
	16	27	5.069	4.261	1.533	4.970	4.428	1.640	4.716	4.361	1.751	4.433	2.978	2.036
	19	27	5.084	4.280	1.534	4.997	4.466	1.641	4.750	4.396	1.931	4.495	3.001	2.037
	22	27	5.135	4.312	1.535	5.045	4.493	1.643	4.793	4.437	1.932	4.500	3.109	2.038
	16	29	5.206	4.630	1.536	5.083	4.588	1.644	4.816	4.484	1.933	4.515	3.178	2.038
	19	29	5.222	4.870	1.536	5.131	4.727	1.643	4.835	4.568	1.935	4.542	3.386	2.042
	22	29	5.249	4.886	1.537	5.142	4.732	1.646	4.844	4.593	1.936	4.552	3.381	2.049
	16	22	5.053	4.435	1.542	4.981	4.319	1.658	4.727	4.437	1.946	4.491	3.082	2.063
	17.2	22	5.075	4.450	1.542	5.002	4.334	1.659	4.752	4.465	1.946	4.515	3.102	2.065
550	16	24.4	5.102	4.466	1.544	5.029	4.354	1.659	4.773	4.498	1.948	4.549	3.120	2.067
	17.2	24.4	5.158	4.505	1.545	5.053	4.386	1.660	4.797	4.515	1.946	4.584	3.158	2.067
	22	24.4	5.245	4.922	1.546	5.142	4.732	1.661	4.859	4.508	1.950	4.613	3.356	2.079
	16	27	5.347	5.019	1.547	5.222	4.821	1.664	4.916	4.527	1.949	4.652	3.335	2.082
	19	27	5.451	5.127	1.548	5.367	4.976	1.664	5.110	4.745	1.952	4.801	3.503	2.084
	22	27	5.465	5.140	1.552	5.379	4.986	1.668	5.119	4.759	1.955	4.808	3.509	2.085
	16	29	5.467	5.050	1.552	5.384	4.983	1.668	5.123	4.764	1.954	4.811	3.512	2.086
	19	29	5.471	5.056	1.552	5.388	4.984	1.669	5.129	4.892	1.942	4.819	3.443	2.073
	22	29	5.501	5.081	1.556	5.415	5.007	1.675	5.151	4.913	1.950	4.838	3.457	2.080

UW18AIHTG00

Indoor Temperature						Outdoor Temperature								
AFR (CFM)	EWB (°C)	EDB (°C)	35°			40°			46°			52°		
			TC	SC	PI	TC	SC	PI	TC	SC	PI	TC	SC	PI
390	16	22	4.764	4.055	1.499	4.580	3.813	1.603	4.303	3.713	1.870	3.975	2.694	1.977
	17.2	22	4.801	4.020	1.504	4.633	3.865	1.608	4.335	3.775	1.874	3.995	2.715	1.978
	16	24.4	4.814	4.128	1.502	4.652	3.925	1.606	4.371	3.808	1.876	4.034	2.798	1.980
	17.2	24.4	4.831	4.149	1.503	4.736	4.041	1.619	4.421	3.871	1.890	4.154	2.858	1.981
	22	24.4	5.044	4.578	1.507	4.906	4.225	1.620	4.527	4.074	1.891	4.230	2.970	1.982
	16	27	5.128	4.636	1.508	4.994	4.483	1.621	4.641	4.160	1.892	4.264	3.057	1.983
	19	27	5.159	4.721	1.509	5.059	4.583	1.622	4.722	4.323	1.892	4.437	3.232	1.984
	22	27	5.168	4.727	1.512	5.067	4.580	1.623	4.730	4.327	1.899	4.446	3.243	1.985
	16	29	5.174	4.615	1.514	5.071	4.478	1.624	4.733	4.308	1.897	4.451	3.146	1.986
	19	29	5.178	4.657	1.515	5.078	4.514	1.624	4.740	4.335	1.893	4.454	3.172	1.987
	22	29	5.184	4.662	1.517	5.099	4.529	1.626	4.792	4.365	1.895	4.485	3.174	1.988
	16	22	5.117	4.275	1.522	5.010	4.397	1.630	4.714	4.312	1.706	4.412	2.905	1.998
460	17.2	22	5.133	4.301	1.522	5.027	4.397	1.630	4.735	4.336	1.710	4.426	2.919	1.999
	16	24.4	5.150	4.327	1.523	5.054	4.428	1.630	4.756	4.374	1.714	4.446	2.939	2.000
	17.2	24.4	5.170	4.357	1.523	5.071	4.463	1.631	4.769	4.410	1.715	4.464	2.958	2.001
	22	24.4	5.189	4.384	1.525	5.093	4.478	1.632	4.782	4.450	1.716	4.485	2.970	2.005
	16	27	5.206	4.348	1.525	5.104	4.519	1.632	4.797	4.374	1.725	4.510	2.988	2.007
	19	27	5.221	4.368	1.526	5.132	4.557	1.633	4.832	4.410	1.904	4.572	3.010	2.007
	22	27	5.273	4.400	1.527	5.181	4.585	1.634	4.875	4.450	1.904	4.577	3.119	2.008
	16	29	5.346	4.724	1.528	5.220	4.681	1.636	4.899	4.498	1.905	4.592	3.188	2.009
	19	29	5.363	4.970	1.528	5.269	4.823	1.634	4.918	4.582	1.907	4.620	3.397	2.012
	22	29	5.391	4.986	1.530	5.280	4.829	1.638	4.927	4.607	1.908	4.630	3.392	2.020
	16	22	5.189	4.526	1.534	5.115	4.407	1.649	4.808	4.450	1.917	4.568	3.091	2.034
	17.2	22	5.212	4.541	1.534	5.137	4.423	1.650	4.834	4.512	1.918	4.593	3.112	2.035
550	16	24.4	5.240	4.557	1.536	5.165	4.443	1.651	4.854	4.512	1.920	4.627	3.129	2.037
	17.2	24.4	5.297	4.597	1.537	5.189	4.476	1.651	4.879	4.529	1.918	4.663	3.168	2.037
	22	24.4	5.386	5.023	1.538	5.280	4.829	1.653	4.943	4.522	1.922	4.693	3.366	2.049
	16	27	5.492	5.122	1.539	5.363	4.920	1.655	5.000	4.541	1.921	4.732	3.345	2.052
	19	27	5.598	5.232	1.540	5.512	5.078	1.656	5.197	4.760	1.924	4.883	3.514	2.054
	22	27	5.612	5.245	1.544	5.525	5.089	1.660	5.207	4.773	1.927	4.891	3.519	2.055
	16	29	5.615	5.154	1.544	5.529	5.085	1.659	5.210	4.778	1.926	4.894	3.523	2.056
	19	29	5.618	5.160	1.544	5.534	5.086	1.661	5.217	4.907	1.914	4.902	3.454	2.043
	22	29	5.649	5.186	1.548	5.561	5.110	1.666	5.239	4.928	1.921	4.921	3.467	2.050

PERFORMANCE TABLES (R32 COOL ONLY INVERTER)

UW24AICTG00

Indoor Temperature						Outdoor Temperature								
AFR (CFM)	EWB (°C)	EDB (°C)	TC	35° SC	PI	TC	40° SC	PI	TC	46° SC	PI	TC	52° SC	PI
590	16	22	6.111	5.404	2.021	5.876	5.082	2.161	5.367	4.823	2.406	4.957	3.500	2.543
	17.2	22	6.158	5.357	2.027	5.944	5.151	2.167	5.406	4.904	2.411	4.982	3.527	2.545
	16	24.4	6.176	5.502	2.024	5.968	5.231	2.165	5.451	4.947	2.413	5.031	3.635	2.548
	17.2	24.4	6.197	5.530	2.026	6.075	5.386	2.183	5.513	5.029	2.432	5.180	3.713	2.549
	22	24.4	6.470	6.101	2.031	6.293	5.630	2.183	5.645	5.293	2.433	5.275	3.859	2.551
	16	27	6.578	6.178	2.032	6.406	5.975	2.185	5.788	5.405	2.435	5.318	3.971	2.552
	19	27	6.618	6.292	2.034	6.490	6.108	2.186	5.889	5.616	2.435	5.533	4.199	2.553
	22	27	6.629	6.300	2.039	6.500	6.104	2.188	5.898	5.621	2.443	5.544	4.213	2.555
	16	29	6.637	6.150	2.041	6.505	5.969	2.190	5.903	5.596	2.441	5.550	4.088	2.556
	19	29	6.642	6.207	2.043	6.514	6.015	2.190	5.911	5.631	2.436	5.554	4.121	2.557
	22	29	6.650	6.213	2.045	6.540	6.036	2.192	5.976	5.670	2.438	5.593	4.124	2.558
	16	22	6.563	5.697	2.051	6.427	5.820	2.197	5.879	5.602	2.196	5.502	3.774	2.571
690	17.2	22	6.585	5.732	2.052	6.448	5.860	2.198	5.905	5.633	2.201	5.520	3.792	2.573
	16	24.4	6.607	5.767	2.053	6.484	5.901	2.198	5.931	5.683	2.206	5.544	3.819	2.574
	17.2	24.4	6.632	5.807	2.053	6.505	5.948	2.199	5.948	5.729	2.207	5.567	3.843	2.574
	22	24.4	6.657	5.843	2.055	6.533	5.969	2.200	5.963	5.782	2.208	5.593	3.859	2.579
	16	27	6.678	5.795	2.056	6.547	6.023	2.200	5.983	5.683	2.220	5.624	3.881	2.582
	19	27	6.697	5.821	2.057	6.583	6.074	2.201	6.025	5.729	2.450	5.702	3.910	2.583
	22	27	6.765	5.864	2.058	6.646	6.111	2.203	6.080	5.782	2.450	5.708	4.052	2.584
	16	29	6.858	6.297	2.060	6.696	6.239	2.205	6.109	5.844	2.451	5.727	4.142	2.585
	19	29	6.879	6.624	2.060	6.759	6.429	2.203	6.133	5.953	2.454	5.761	4.413	2.589
	22	29	6.915	6.645	2.062	6.774	6.436	2.208	6.145	5.986	2.456	5.774	4.406	2.599
	16	22	6.657	6.032	2.068	6.562	5.874	2.223	5.995	5.782	2.467	5.697	4.016	2.617
	17.2	22	6.686	6.053	2.068	6.590	5.894	2.224	6.028	5.819	2.468	5.728	4.043	2.618
830	16	24.4	6.721	6.073	2.070	6.625	5.921	2.225	6.054	5.862	2.470	5.770	4.065	2.622
	17.2	24.4	6.796	6.127	2.071	6.657	5.966	2.226	6.085	5.884	2.468	5.815	4.116	2.622
	22	24.4	6.910	6.695	2.074	6.774	6.436	2.228	6.164	5.875	2.473	5.852	4.373	2.637
	16	27	7.045	6.827	2.074	6.880	6.557	2.232	6.235	5.899	2.472	5.901	4.346	2.641
	19	27	7.181	6.973	2.076	7.071	6.767	2.232	6.482	6.184	2.475	6.089	4.565	2.643
	22	27	7.199	6.990	2.081	7.087	6.782	2.237	6.493	6.201	2.480	6.099	4.572	2.644
	16	29	7.203	6.868	2.081	7.093	6.778	2.237	6.498	6.208	2.478	6.103	4.577	2.646
	19	29	7.207	6.877	2.081	7.099	6.778	2.239	6.506	6.375	2.463	6.113	4.487	2.629
	22	29	7.247	6.911	2.087	7.133	6.810	2.246	6.534	6.402	2.473	6.137	4.505	2.639

UW24AIHTG00

Indoor Temperature						Outdoor Temperature								
AFR (CFM)	EWB (°C)	EDB (°C)	TC	35° SC	PI	TC	40° SC	PI	TC	46° SC	PI	TC	52° SC	PI
590	16	22	5.737	5.123	1.805	5.516	4.818	1.930	5.029	4.451	2.255	4.645	3.230	2.383
	17.2	22	5.781	5.078	1.810	5.579	4.883	1.936	5.065	4.526	2.260	4.668	3.255	2.385
	16	24.4	5.797	5.215	1.808	5.602	4.959	1.934	5.108	4.565	2.262	4.714	3.354	2.388
	17.2	24.4	5.817	5.242	1.810	5.703	5.105	1.949	5.166	4.641	2.279	4.854	3.427	2.389
	22	24.4	6.074	5.784	1.814	5.907	5.337	1.950	5.290	4.885	2.280	4.943	3.561	2.391
	16	27	6.175	5.856	1.815	6.013	5.664	1.952	5.423	4.987	2.281	4.983	3.665	2.392
	19	27	6.212	5.965	1.817	6.092	5.790	1.952	5.518	5.183	2.281	5.184	3.875	2.392
	22	27	6.223	5.972	1.821	6.102	5.786	1.954	5.527	5.187	2.289	5.195	3.888	2.394
	16	29	6.230	5.830	1.822	6.106	5.658	1.956	5.531	5.164	2.287	5.201	3.772	2.395
	19	29	6.235	5.883	1.824	6.115	5.702	1.956	5.539	5.197	2.282	5.204	3.803	2.396
	22	29	6.242	5.890	1.826	6.140	5.722	1.958	5.599	5.233	2.285	5.241	3.805	2.397
	16	22	6.161	5.400	1.832	6.033	5.517	1.962	5.508	5.170	2.057	5.155	3.482	2.409
690	17.2	22	6.181	5.433	1.832	6.053	5.555	1.963	5.533	5.199	2.062	5.172	3.499	2.411
	16	24.4	6.202	5.466	1.833	6.086	5.594	1.963	5.557	5.244	2.067	5.195	3.524	2.412
	17.2	24.4	6.226	5.505	1.834	6.106	5.639	1.964	5.573	5.287	2.068	5.216	3.546	2.412
	22	24.4	6.249	5.539	1.835	6.133	5.658	1.964	5.587	5.336	2.069	5.241	3.561	2.417
	16	27	6.269	5.493	1.836	6.146	5.709	1.965	5.605	5.244	2.081	5.269	3.582	2.420
	19	27	6.287	5.518	1.837	6.180	5.758	1.966	5.646	5.287	2.295	5.342	3.609	2.420
	22	27	6.350	5.559	1.838	6.239	5.793	1.967	5.697	5.336	2.296	5.348	3.739	2.422
	16	29	6.438	5.969	1.840	6.286	5.915	1.970	5.724	5.393	2.297	5.366	3.822	2.422
	19	29	6.458	6.279	1.840	6.345	6.094	1.968	5.746	5.494	2.300	5.398	4.072	2.426
	22	29	6.492	6.299	1.841	6.359	6.101	1.972	5.757	5.524	2.301	5.410	4.066	2.436
	16	22	6.249	5.718	1.847	6.159	5.568	1.985	5.618	5.336	2.312	5.338	3.706	2.452
	17.2	22	6.276	5.737	1.847	6.186	5.587	1.986	5.648	5.370	2.313	5.367	3.731	2.454
830	16	24.4	6.310	5.757	1.849	6.219	5.613	1.988	5.672	5.410	2.315	5.407	3.752	2.457
	17.2	24.4	6.379	5.808	1.850	6.249	5.655	1.988	5.702	5.430	2.313	5.449	3.798	2.457
	22	24.4	6.486	6.346	1.852	6.359	6.101	1.989	5.776	5.421	2.317	5.483	4.036	2.471
	16	27	6.613	6.471	1.852	6.458	6.216	1.993	5.842	5.444	2.316	5.529	4.011	2.475
	19	27	6.741	6.610	1.854	6.637	6.415	1.993	6.073	5.707	2.320	5.706	4.213	2.476
	22	27	6.758	6.627	1.859	6.653	6.429	1.998	6.084	5.722	2.324	5.715	4.219	2.478
	16	29	6.761	6.511	1.859	6.658	6.425	1.997	6.088	5.729	2.322	5.718	4.224	2.480
	19	29	6.765	6.519	1.858	6.664	6.425	1.999	6.096	5.883	2.308	5.728	4.141	2.463
	22	29	6.803	6.551	1.864	6.696	6.456	2.006	6.122	5.908	2.317	5.750	4.157	2.473

PERFORMANCE TABLES (R32 COOL ONLY INVERTER)

UW30AICTG00

Indoor Temperature						Outdoor Temperature								
AFR (CFM)	EWB (°C)	EDB (°C)	35°			40°			46°			52°		
			TC	SC	PI	TC	SC	PI	TC	SC	PI	TC	SC	PI
660	16	22	7.482	6.498	2.355	7.194	6.111	2.518	6.165	5.315	2.707	5.695	3.857	2.862
	17.2	22	7.540	6.441	2.362	7.277	6.193	2.525	6.211	5.404	2.713	5.723	3.887	2.864
	16	24.4	7.561	6.615	2.359	7.306	6.290	2.523	6.262	5.451	2.715	5.779	4.005	2.867
	17.2	24.4	7.587	6.649	2.361	7.438	6.476	2.543	6.334	5.542	2.736	5.951	4.092	2.868
	22	24.4	7.922	7.336	2.367	7.705	6.770	2.544	6.485	5.833	2.738	6.060	4.252	2.870
	16	27	8.053	7.428	2.368	7.843	7.185	2.546	6.649	5.956	2.739	6.109	4.376	2.871
	19	27	8.103	7.565	2.371	7.946	7.344	2.547	6.765	6.189	2.739	6.356	4.627	2.872
	22	27	8.117	7.575	2.375	7.958	7.339	2.549	6.776	6.194	2.749	6.369	4.643	2.874
	16	29	8.126	7.395	2.378	7.964	7.176	2.552	6.781	6.167	2.746	6.376	4.505	2.875
	19	29	8.132	7.462	2.380	7.975	7.233	2.552	6.791	6.206	2.740	6.380	4.541	2.876
	22	29	8.141	7.470	2.383	8.008	7.258	2.554	6.865	6.249	2.743	6.425	4.544	2.878
	16	22	8.036	6.850	2.390	7.869	6.997	2.560	6.753	6.174	2.470	6.320	4.158	2.893
17.2	22	8.062	6.892	2.391	7.895	7.046	2.561	6.783	6.208	2.476	6.341	4.178	2.894	
16	24.4	8.089	6.934	2.392	7.938	7.095	2.561	6.813	6.262	2.482	6.369	4.208	2.896	
17.2	24.4	8.120	6.982	2.392	7.964	7.152	2.562	6.832	6.313	2.483	6.395	4.235	2.896	
22	24.4	8.150	7.026	2.395	7.999	7.176	2.563	6.850	6.371	2.484	6.425	4.252	2.902	
16	27	8.177	6.967	2.395	8.016	7.241	2.564	6.873	6.262	2.498	6.461	4.277	2.905	
19	27	8.199	6.999	2.397	8.060	7.303	2.565	6.922	6.313	2.756	6.550	4.309	2.906	
22	27	8.282	7.051	2.398	8.137	7.347	2.567	6.984	6.371	2.757	6.557	4.465	2.908	
16	29	8.396	7.571	2.401	8.198	7.502	2.570	7.018	6.439	2.758	6.579	4.564	2.908	
19	29	8.422	7.964	2.401	8.275	7.729	2.567	7.045	6.560	2.761	6.619	4.863	2.913	
22	29	8.467	7.990	2.403	8.293	7.738	2.572	7.059	6.596	2.763	6.633	4.856	2.924	
16	22	8.150	7.252	2.409	8.034	7.062	2.591	6.888	6.371	2.776	6.545	4.425	2.944	
17.2	22	8.185	7.277	2.410	8.068	7.087	2.592	6.925	6.412	2.777	6.580	4.455	2.946	
16	24.4	8.229	7.302	2.412	8.111	7.119	2.593	6.955	6.460	2.779	6.629	4.480	2.950	
17.2	24.4	8.320	7.367	2.414	8.150	7.173	2.594	6.990	6.484	2.777	6.680	4.535	2.949	
22	24.4	8.460	8.049	2.417	8.293	7.738	2.596	7.081	6.474	2.782	6.723	4.819	2.967	
16	27	8.625	8.208	2.417	8.423	7.884	2.600	7.163	6.501	2.781	6.779	4.789	2.971	
19	27	8.792	8.384	2.419	8.657	8.136	2.601	7.446	6.814	2.785	6.996	5.031	2.973	
22	27	8.814	8.405	2.425	8.677	8.154	2.607	7.459	6.833	2.790	7.006	5.038	2.975	
16	29	8.818	8.258	2.425	8.684	8.149	2.606	7.465	6.841	2.788	7.011	5.044	2.977	
19	29	8.824	8.268	2.425	8.691	8.150	2.609	7.474	7.025	2.771	7.022	4.945	2.958	
22	29	8.872	8.310	2.432	8.734	8.188	2.617	7.506	7.055	2.782	7.050	4.964	2.969	

UW30AIHTG00

Indoor Temperature						Outdoor Temperature								
AFR (CFM)	EWB (°C)	EDB (°C)	35°			40°			46°			52°		
			TC	SC	PI	TC	SC	PI	TC	SC	PI	TC	SC	PI
640	16	22	7.482	6.472	2.355	7.194	6.086	2.518	6.286	5.483	2.818	5.806	3.979	2.979
	17.2	22	7.540	6.416	2.362	7.277	6.169	2.525	6.332	5.575	2.825	5.835	4.009	2.981
	16	24.4	7.561	6.589	2.359	7.306	6.265	2.523	6.384	5.624	2.827	5.892	4.132	2.984
	17.2	24.4	7.587	6.623	2.361	7.438	6.450	2.543	6.457	5.717	2.849	6.067	4.221	2.986
	22	24.4	7.922	7.307	2.367	7.705	6.743	2.544	6.612	6.017	2.850	6.179	4.387	2.988
	16	27	8.053	7.399	2.368	7.843	7.156	2.546	6.779	6.144	2.852	6.229	4.514	2.989
	19	27	8.103	7.536	2.371	7.946	7.315	2.547	6.898	6.384	2.852	6.480	4.774	2.991
	22	27	8.117	7.545	2.375	7.958	7.310	2.549	6.908	6.390	2.862	6.494	4.790	2.992
	16	29	8.126	7.366	2.378	7.964	7.148	2.552	6.913	6.362	2.859	6.501	4.647	2.994
	19	29	8.132	7.433	2.380	7.975	7.204	2.552	6.923	6.402	2.853	6.505	4.685	2.995
	22	29	8.141	7.441	2.383	8.008	7.229	2.554	6.999	6.446	2.856	6.551	4.688	2.996
	16	22	8.036	6.823	2.390	7.869	6.970	2.560	6.885	6.369	2.572	6.444	4.290	3.012
17.2	22	8.062	6.865	2.391	7.895	7.018	2.561	6.916	6.404	2.578	6.465	4.310	3.013	
16	24.4	8.089	6.906	2.392	7.938	7.067	2.561	6.946	6.460	2.584	6.494	4.341	3.015	
17.2	24.4	8.120	6.955	2.392	7.964	7.124	2.562	6.966	6.513	2.585	6.520	4.369	3.016	
22	24.4	8.150	6.998	2.395	7.999	7.148	2.563	6.984	6.573	2.586	6.551	4.387	3.021	
16	27	8.177	6.940	2.395	8.016	7.213	2.564	7.007	6.460	2.601	6.587	4.412	3.024	
19	27	8.199	6.972	2.397	8.060	7.274	2.565	7.057	6.513	2.869	6.678	4.445	3.025	
22	27	8.282	7.023	2.398	8.137	7.318	2.567	7.121	6.573	2.870	6.686	4.606	3.027	
16	29	8.396	7.541	2.401	8.198	7.472	2.570	7.155	6.643	2.871	6.708	4.708	3.028	
19	29	8.422	7.933	2.401	8.275	7.699	2.567	7.183	6.767	2.875	6.748	5.017	3.033	
22	29	8.467	7.959	2.403	8.293	7.707	2.572	7.197	6.805	2.876	6.762	5.009	3.045	
16	22	8.150	7.224	2.409	8.034	7.035	2.591	7.022	6.573	2.890	6.673	4.565	3.065	
17.2	22	8.185	7.249	2.410	8.068	7.059	2.592	7.060	6.615	2.891	6.708	4.596	3.067	
16	24.4	8.229	7.274	2.412	8.111	7.091	2.593	7.090	6.664	2.894	6.759	4.621	3.071	
17.2	24.4	8.320	7.338	2.414	8.150	7.145	2.594	7.127	6.689	2.891	6.811	4.679	3.071	
22	24.4	8.460	8.018	2.417	8.293	7.707	2.596	7.219	6.678	2.897	6.854	4.972	3.089	
16	27	8.625	8.176	2.417	8.423	7.853	2.600	7.303	6.706	2.896	6.911	4.941	3.093	
19	27	8.792	8.351	2.419	8.657	8.104	2.601	7.591	7.030	2.899	7.132	5.190	3.095	
22	27	8.814	8.372	2.425	8.677	8.122	2.607	7.605	7.049	2.905	7.143	5.198	3.097	
16	29	8.818	8.226	2.425	8.684	8.117	2.606	7.610	7.057	2.903	7.148	5.203	3.099	
19	29	8.824	8.236	2.425	8.691	8.118	2.609	7.620	7.247	2.885	7.159	5.101	3.079	
22	29	8.872	8.277	2.432	8.734	8.156	2.617	7.653	7.277	2.896	7.188	5.121	3.091	

PERFORMANCE TABLES (R32 COOL ONLY INVERTER)

UW36AICTG00

Indoor Temperature						Outdoor Temperature								
AFR (CFM)	EWB (°C)	EDB (°C)	TC	35° SC	PI	TC	40° SC	PI	TC	46° SC	PI	TC	52° SC	PI
770	16	22	8.979	7.770	2.826	8.633	7.307	3.021	7.737	6.733	3.469	7.147	4.886	3.667
	17.2	22	9.048	7.703	2.835	8.733	7.406	3.031	7.793	6.846	3.477	7.182	4.923	3.670
	16	24.4	9.074	7.911	2.830	8.768	7.521	3.028	7.858	6.906	3.480	7.252	5.074	3.673
	17.2	24.4	9.104	7.951	2.833	8.926	7.744	3.052	7.948	7.021	3.507	7.468	5.183	3.676
	22	24.4	9.506	8.773	2.840	9.246	8.095	3.053	8.138	7.389	3.508	7.605	5.387	3.678
	16	27	9.665	8.883	2.842	9.412	8.592	3.056	8.344	7.544	3.510	7.667	5.543	3.679
	19	27	9.724	9.047	2.845	9.536	8.782	3.057	8.490	7.840	3.510	7.976	5.862	3.681
	22	27	9.741	9.058	2.851	9.550	8.776	3.060	8.503	7.847	3.522	7.993	5.882	3.683
	16	29	9.751	8.843	2.854	9.558	8.582	3.062	8.509	7.812	3.519	8.001	5.706	3.685
	19	29	9.759	8.924	2.857	9.571	8.649	3.062	8.522	7.861	3.512	8.007	5.753	3.686
	22	29	9.770	8.933	2.859	9.610	8.679	3.065	8.615	7.916	3.515	8.063	5.756	3.688
	900	16	22	9.644	8.191	2.868	9.443	8.368	3.073	8.475	7.821	3.166	7.931	5.268
17.2		22	9.675	8.241	2.869	9.475	8.426	3.073	8.512	7.864	3.173	7.957	5.293	3.709
16		24.4	9.707	8.292	2.870	9.527	8.485	3.074	8.550	7.933	3.181	7.993	5.330	3.711
17.2		24.4	9.745	8.350	2.871	9.558	8.553	3.075	8.574	7.998	3.182	8.025	5.365	3.712
22		24.4	9.781	8.402	2.874	9.599	8.582	3.076	8.596	8.071	3.183	8.063	5.387	3.719
16		27	9.812	8.332	2.875	9.620	8.660	3.076	8.624	7.933	3.201	8.107	5.418	3.723
19		27	9.840	8.370	2.877	9.672	8.733	3.078	8.686	7.998	3.532	8.219	5.459	3.724
22		27	9.939	8.432	2.878	9.765	8.786	3.080	8.764	8.071	3.533	8.229	5.656	3.726
16		29	10.076	9.053	2.881	9.838	8.971	3.084	8.807	8.157	3.534	8.256	5.781	3.727
19		29	10.107	9.524	2.881	9.931	9.243	3.081	8.841	8.310	3.538	8.305	6.160	3.733
22		29	10.161	9.555	2.883	9.952	9.253	3.087	8.858	8.356	3.540	8.323	6.151	3.747
16		22	9.781	8.672	2.891	9.641	8.446	3.109	8.643	8.071	3.557	8.213	5.606	3.773
17.2	22	9.823	8.703	2.892	9.682	8.475	3.110	8.690	8.123	3.559	8.257	5.644	3.775	
16	24.4	9.876	8.733	2.895	9.734	8.514	3.111	8.727	8.183	3.562	8.319	5.675	3.780	
17.2	24.4	9.985	8.810	2.897	9.781	8.578	3.112	8.772	8.214	3.559	8.383	5.745	3.780	
22	24.4	10.152	9.626	2.900	9.952	9.253	3.115	8.886	8.200	3.565	8.436	6.105	3.802	
16	27	10.351	9.815	2.900	10.108	9.428	3.120	8.989	8.235	3.564	8.506	6.067	3.807	
19	27	10.551	10.026	2.903	10.389	9.730	3.121	9.344	8.632	3.569	8.779	6.373	3.810	
22	27	10.577	10.051	2.910	10.413	9.751	3.128	9.361	8.656	3.575	8.792	6.382	3.812	
16	29	10.583	9.876	2.910	10.421	9.745	3.128	9.367	8.666	3.573	8.798	6.389	3.815	
19	29	10.589	9.887	2.910	10.430	9.746	3.131	9.379	8.899	3.551	8.812	6.264	3.790	
22	29	10.647	9.937	2.918	10.481	9.792	3.141	9.419	8.936	3.565	8.847	6.288	3.804	

UW36AIHTG00

Indoor Temperature						Outdoor Temperature								
AFR (CFM)	EWB (°C)	EDB (°C)	TC	35° SC	PI	TC	40° SC	PI	TC	46° SC	PI	TC	52° SC	PI
770	16	22	9.104	7.937	2.865	8.753	7.464	3.063	7.833	6.794	3.478	7.236	4.930	3.676
	17.2	22	9.174	7.868	2.874	8.854	7.565	3.072	7.891	6.907	3.485	7.271	4.968	3.679
	16	24.4	9.200	8.080	2.869	8.890	7.683	3.069	7.956	6.968	3.488	7.343	5.119	3.683
	17.2	24.4	9.231	8.122	2.872	9.051	7.910	3.094	8.047	7.084	3.516	7.561	5.230	3.685
	22	24.4	9.639	8.961	2.879	9.375	8.269	3.095	8.240	7.455	3.517	7.700	5.435	3.687
	16	27	9.799	9.074	2.881	9.543	8.776	3.098	8.448	7.612	3.519	7.762	5.593	3.689
	19	27	9.859	9.241	2.884	9.669	8.971	3.099	8.596	7.910	3.519	8.076	5.915	3.690
	22	27	9.876	9.253	2.890	9.683	8.965	3.102	8.609	7.917	3.531	8.092	5.935	3.693
	16	29	9.887	9.033	2.893	9.691	8.766	3.104	8.615	7.882	3.528	8.101	5.758	3.694
	19	29	9.895	9.115	2.896	9.704	8.835	3.104	8.628	7.932	3.521	8.106	5.805	3.695
	22	29	9.906	9.125	2.899	9.744	8.865	3.107	8.722	7.987	3.524	8.164	5.808	3.697
	16	22	9.778	8.367	2.908	9.575	8.547	3.115	8.581	7.891	3.174	8.030	5.315	3.716
17.2	22	9.810	8.418	2.909	9.607	8.607	3.115	8.618	7.934	3.181	8.057	5.340	3.718	
16	24.4	9.842	8.469	2.910	9.659	8.667	3.116	8.656	8.004	3.189	8.092	5.378	3.720	
17.2	24.4	9.881	8.529	2.911	9.691	8.736	3.117	8.681	8.069	3.190	8.126	5.413	3.721	
22	24.4	9.917	8.582	2.914	9.733	8.766	3.118	8.704	8.144	3.191	8.164	5.435	3.728	
16	27	9.949	8.510	2.914	9.754	8.845	3.119	8.732	8.004	3.209	8.208	5.467	3.732	
19	27	9.977	8.549	2.917	9.807	8.921	3.120	8.794	8.069	3.541	8.322	5.508	3.733	
22	27	10.078	8.613	2.918	9.902	8.975	3.123	8.874	8.144	3.542	8.331	5.707	3.736	
16	29	10.217	9.248	2.921	9.975	9.163	3.126	8.916	8.231	3.543	8.359	5.833	3.736	
19	29	10.248	9.728	2.921	10.069	9.441	3.123	8.951	8.385	3.547	8.409	6.216	3.742	
22	29	10.302	9.760	2.923	10.091	9.452	3.130	8.968	8.431	3.549	8.427	6.206	3.757	
900	16	22	9.917	8.858	2.931	9.775	8.627	3.152	8.751	8.144	3.566	8.315	5.656	3.783
	17.2	22	9.960	8.889	2.932	9.817	8.657	3.153	8.798	8.196	3.568	8.360	5.694	3.785
	16	24.4	10.013	8.920	2.935	9.870	8.696	3.154	8.836	8.257	3.571	8.422	5.726	3.790
	17.2	24.4	10.124	8.999	2.936	9.917	8.762	3.155	8.881	8.288	3.568	8.488	5.797	3.789
	22	24.4	10.294	9.832	2.940	10.091	9.452	3.158	8.997	8.274	3.574	8.541	6.160	3.812
	16	27	10.495	10.026	2.940	10.249	9.631	3.163	9.101	8.309	3.573	8.613	6.121	3.817
	19	27	10.698	10.241	2.943	10.534	9.939	3.164	9.460	8.710	3.578	8.888	6.430	3.819
	22	27	10.725	10.267	2.951	10.558	9.960	3.171	9.477	8.734	3.584	8.902	6.440	3.822
	16	29	10.730	10.087	2.950	10.566	9.954	3.171	9.484	8.744	3.582	8.908	6.447	3.825
	19	29	10.737	10.100	2.950	10.575	9.955	3.174	9.496	8.979	3.560	8.922	6.320	3.800
	22	29	10.796	10.150	2.958	10.627	10.002	3.184	9.537	9.017	3.574	8.958	6.345	3.814

WIRING DIAGRAMS

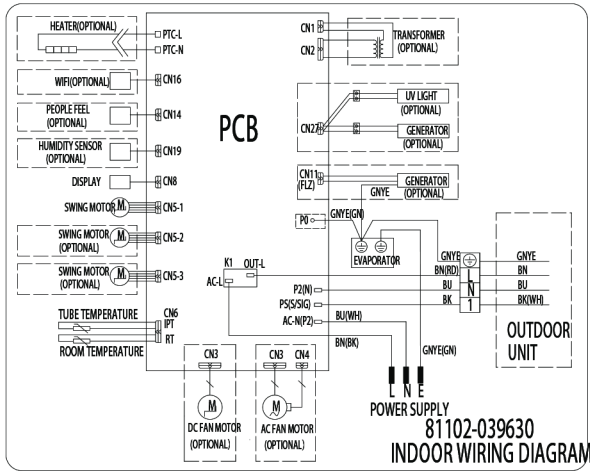

**UINW12AICTG0-Q
 UINW18AICTG00-Q**

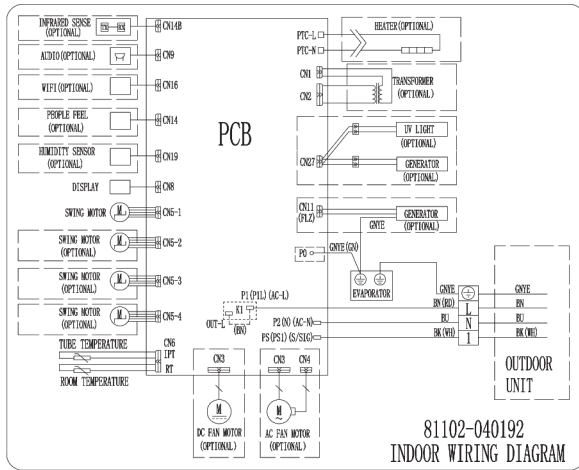

UINW24AICTG00-Q

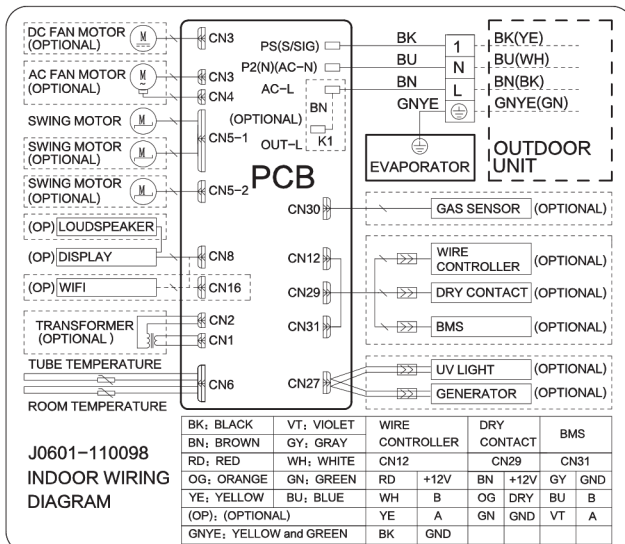

**UINW30AICTG00-Q
 UINW36AICTG00-Q**

WIRING DIAGRAMS

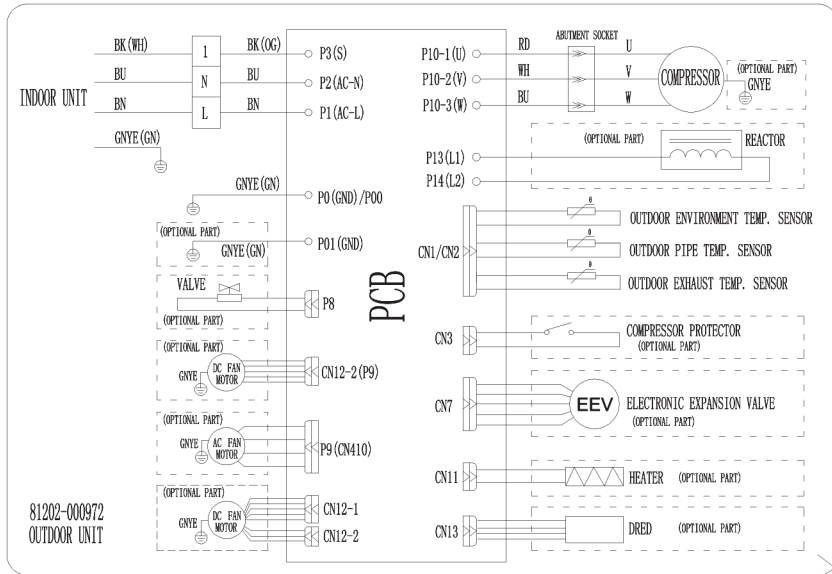

UONW12AICTG00-Q
UONW18AICTG00-Q

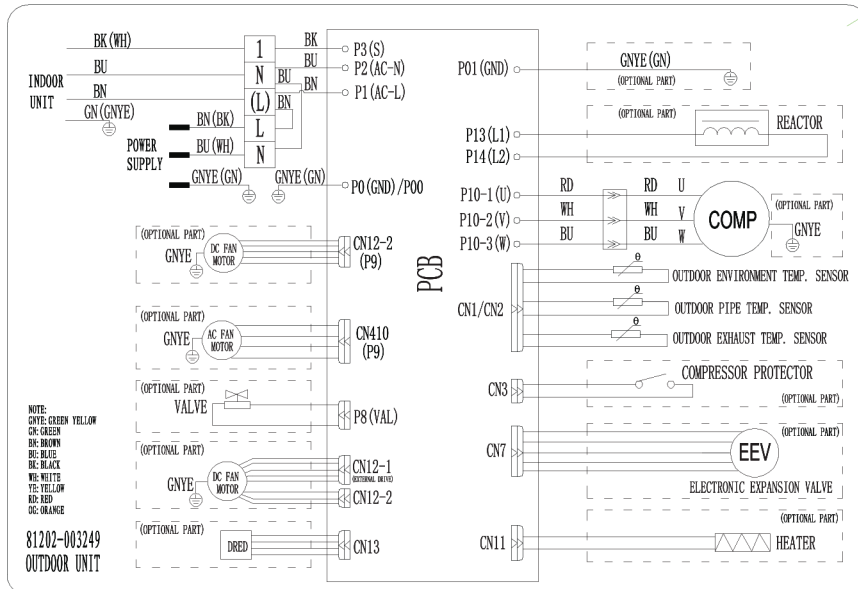

UONW24AICTG00-Q
UONW36AICTG00-Q
UONW30AICTG00-Q



@RUUDmea



www.RUUD-mea.com



RUUD Middle East & Africa

UAE: RMEA Manufacturing LLC | Onyx 2, Level P3 301-304, The Greens Dubai, UAEA | Tel: +971 4 230 5100
KSA: Ruud Innovation and Learning Centre | Riyadh Building 14, Business District, Airport Road, Riyadh, KSA | Tel: +966 11 494 5222